

Design Approval: **ALL CUSTOM DESIGNS ARE NON-CANCELLABLE AND NON-RETURNABLE.** This endorsed approval drawing must be received in order to release your order for production. Manufacturer reserves the right to alter design to current manufacturing standards. By signing, you certify your approval in the following areas:

-Overall Dimensions -Hardware (fixtures, casters, accessories)
 -Material -Delivery Access (will it fit through doors)
 -Construction and Design -Facility Integration (rough in alignment, etc)

Approval Signature _____ Date: _____
 Print Name and Title _____
 (Signature, Date, Printed Name & Title are all required)

AAMI COMPLIANT FOR:
 HEIGHT
 SINK BOWL DEPTH

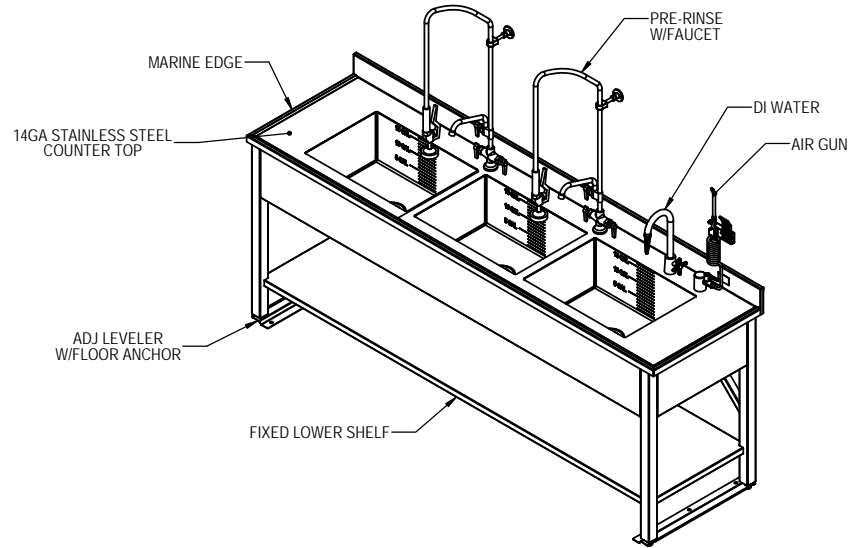
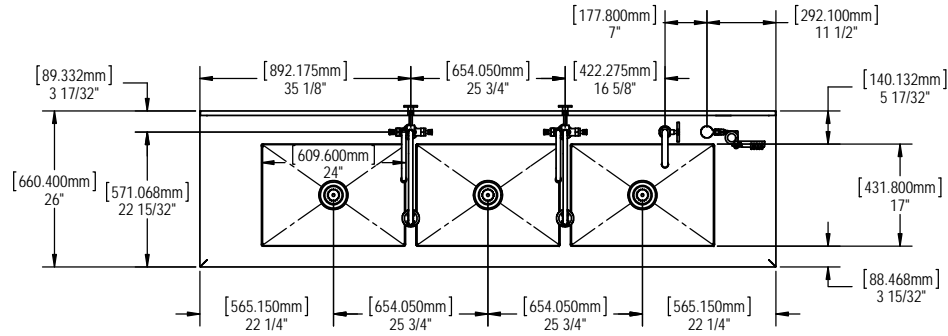

NOTES:

- FULLY WELDED 304 SERIES STAINLESS STEEL CONSTRUCTION
- PRE-RINSE FAUCETS: GOOSE NECK WITH BUILT IN PRERINSE INLET - 1/2" NPSM MALE WITH COMPRESSION FITTINGS. OPERATING PRESSURE 20-125 PSI OPERATING TEMP RANGE 40-180° F
- TREATED (DI) WATER: FLOW RATE 50 PSI - 120 PSI, RATE OPERATING PRESSURE: 20-125 PSI, RATED OPERATING TEMPERATURE: 40-140° F, 1/2" NPSM MALE INLET, OPTIONAL ADAPTER FOR 1/4" NPT MALE INLET (INCLUDED)
- AIR INLET: TURRET BASE 3/8" NPT FEMALE INLET SINGLE 3/8" NPT FEMALE OUTLET, 3/8" IPS MOUNTING SHANK WITH LOCKNUT AN WASHER, 3/8" PS X 2-1/2" OAL, LOW-PRESSURE BRASS THREADED PIPE FITTING 3/8 MALE X 1/4 FEM PIPE SIZE, HEX REDUCING BUSHING
- GOOSE NECK FAUCET: 1/2" NPSM MALE INLET
- SINK DRAIN: SINK OPENING DIAMETER 3-1/2", NPS: 1-1/2" FACE FLANGE DIAMETER: 4-1/2"
- UTILITY REQUIREMENT: COLD WATER - 20 TO 50 PSIG 70° F MAX, HOT WATER - 20 TO 50 PSIG 120° F TO 140° F.
- AIR GUN WITH STANDARD 5 TIP GUN & HOSE: CONNECTIONS ARE TO BE MADE PER LOCAL CODE & NOT TO EXCEED RECOMANDED 150 PSI, 1/4" NPTF INLET

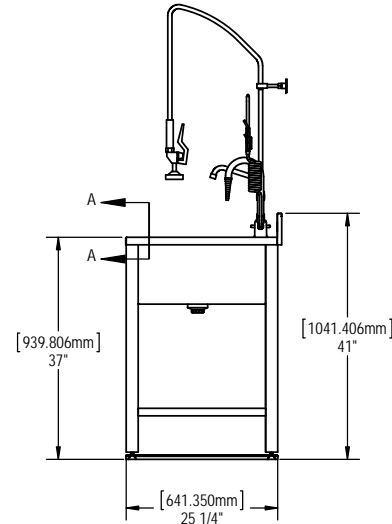
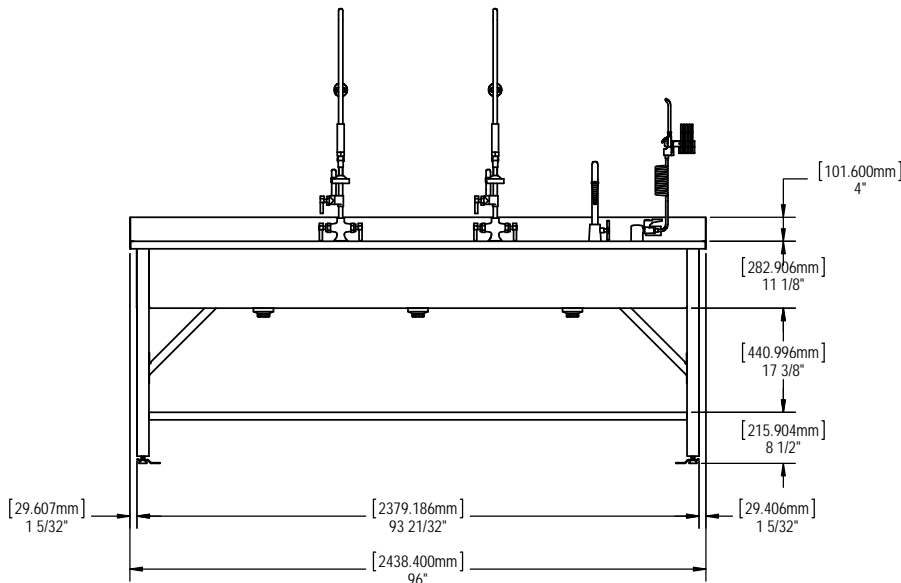

AA	RELEASE FOR PRODUCTION		D.QUALLS	5/3/16
REV.	DESCRIPTION	ECO #	BY:	DATE
REVISIONS				

WEIGHT (LBS) 292.02	THIRD ANGLE PROJECTION	INCHES	MATERIAL	FINISH
------------------------	------------------------	--------	----------	--------

TITLE
PROCESSING SINK TRIPLE BASIN

TOLERANCES UNLESS OTHERWISE SPECIFIED		DATE
ANGLES: ±1°	DECIMALS: .XXX = ±.003	4/12/16
FRACTIONS: ± 1/64	DECIMALS: .XXX = ±.015	
	DECIMALS: .XXX = ±.005	
DRAWN BY	D.QUALLS	DATE
CHECKED BY		DATE
APPROVED BY		DATE
DRAWING NUMBER	SCALE 1:16	SHEET 1 OF 2
FHCPS269637-1-1-3-2		

CONFIDENTIAL & PROPRIETARY TO FHC NOT TO BE COPIED OR SHOWN TO ANYONE WITHOUT THE EXPRESS PERMISSION OF FHC

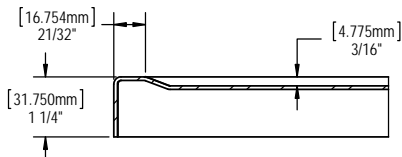

SECTION A-A
SCALE 1 : 2
MARINE EDGE DETAIL

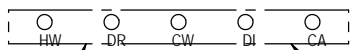
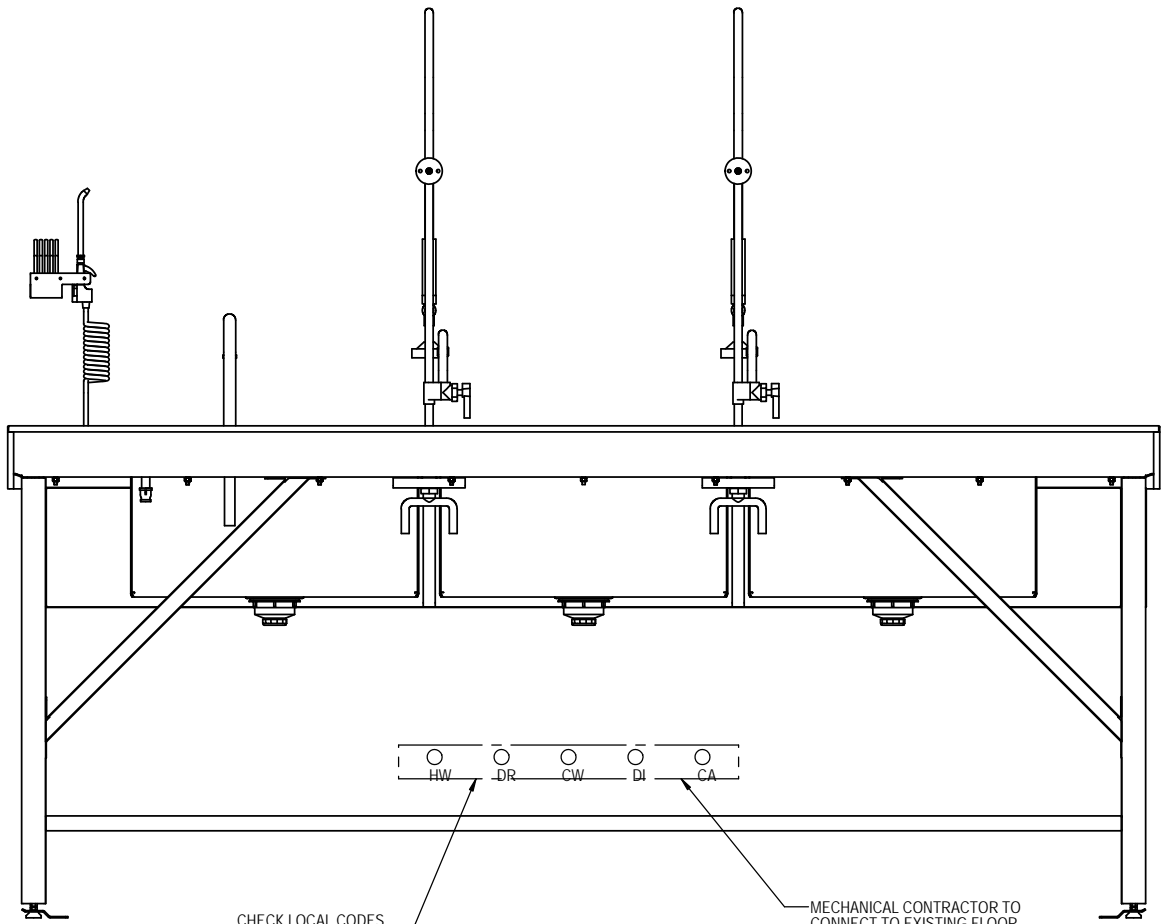

CHECK LOCAL CODES FOR LOCATION

MECHANICAL CONTRACTOR TO CONNECT TO EXISTING FLOOR OR WALL DRAIN IN ACCORDANCE WITH APPLICABLE LOCAL CODE STANDARDS.

RECOMMENDATIONS:

1. UTILITY CONNECTION: BRAIDED HOSES ARE USED. THEY NEED TO HAVE 12" TO 13" OF PLAY IN ORDER TO ALLOW SINK TO RAISE AND LOWER.
2. CHECK ALL LOCAL CODES.

WEIGHT (LBS) 292.02	THIRD ANGLE PROJECTION	INCHES	MATERIAL	FINISH
------------------------	------------------------	--------	----------	--------

TITLE
PROCESSING SINK TRIPLE BASIN

ANY PHYSICAL, DIMENSIONAL OR PERFORMANCE SPECIFICATIONS SHALL NOT BE REVISED WITHOUT WRITTEN AUTHORIZATION FROM MAC MEDICAL ENGINEERING

TOLERANCES UNLESS OTHERWISE SPECIFIED		DATE
ANGLES: ±1°	DECIMALS: .XX = ±.005	5/2/2016
FRACTIONS: ± 1/64	DECIMALS: .XXX = ±.015	DATE
	DECIMALS: .XXXX = ±.005	DATE
	DRAWN BY	DATE
	CHECKED BY	DATE
	APPROVED BY	DATE
SCALE	1:12	SHEET
		2 OF 2

DRAWING NUMBER
FHCPS269637-1-1-3-2

CONFIDENTIAL & PROPRIETARY TO FHC. NOT TO BE COPIED OR SHOWN TO ANYONE WITHOUT THE EXPRESS PERMISSION OF FHC