

Design Approval: **ALL CUSTOM DESIGNS ARE NON-CANCELLABLE AND NON-RETURNABLE.** This endorsed approval drawing must be received in order to release your order for production. Manufacturer reserves the right to alter design to current manufacturing standards. By signing, you certify your approval in the following areas:

-Overall Dimensions -Hardware (fixtures, casters, accessories)
 -Material -Delivery Access (will it fit through doors)
 -Construction and Design -Facility Integration (rough in alignment, etc)

Approval Signature _____ Date: _____
 Print Name and Title _____
 (Signature, Date, Printed Name & Title are all required)

AAMI COMPLIANT FOR:
 HEIGHT
 SINK BOWL DEPTH

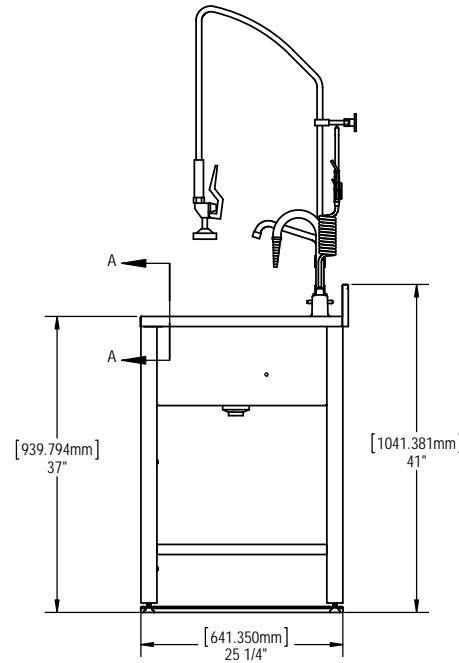
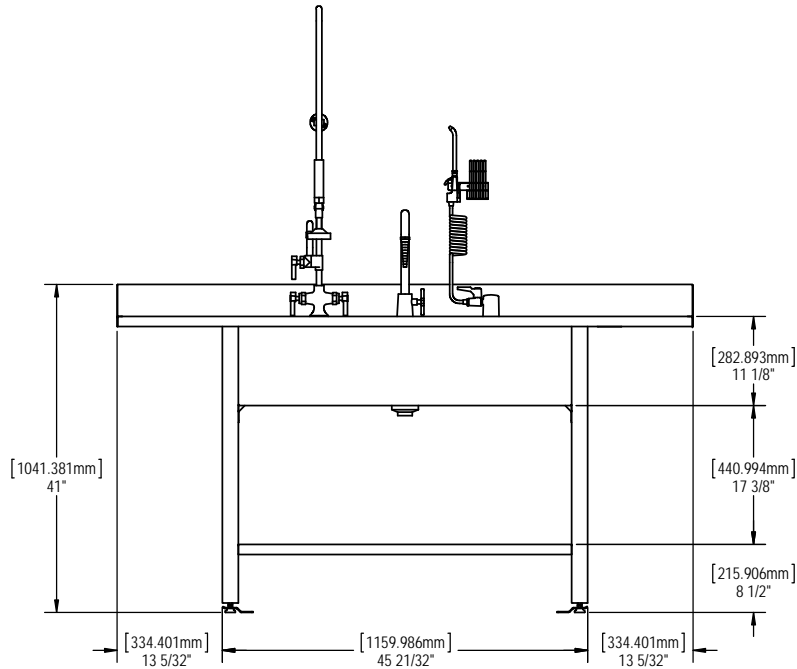
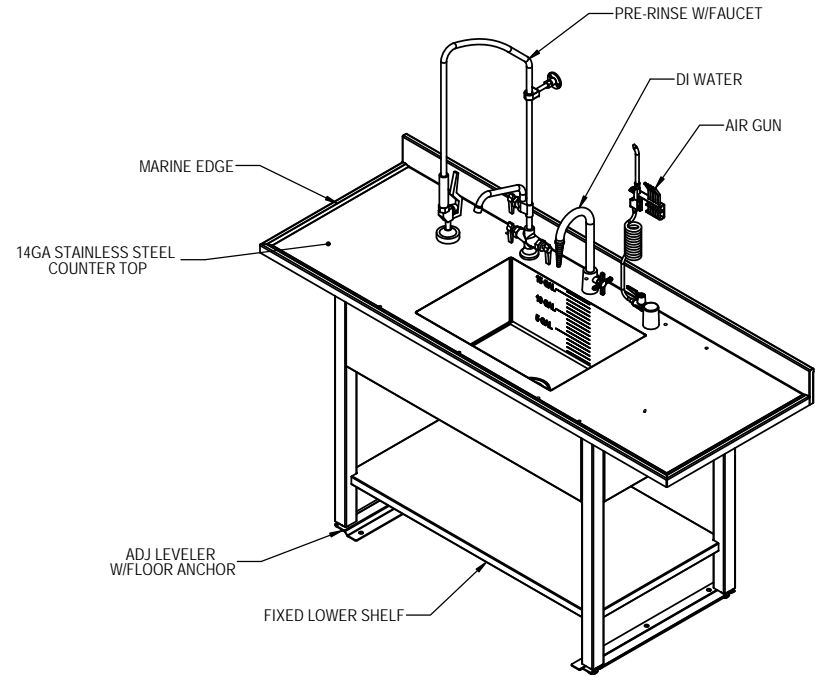
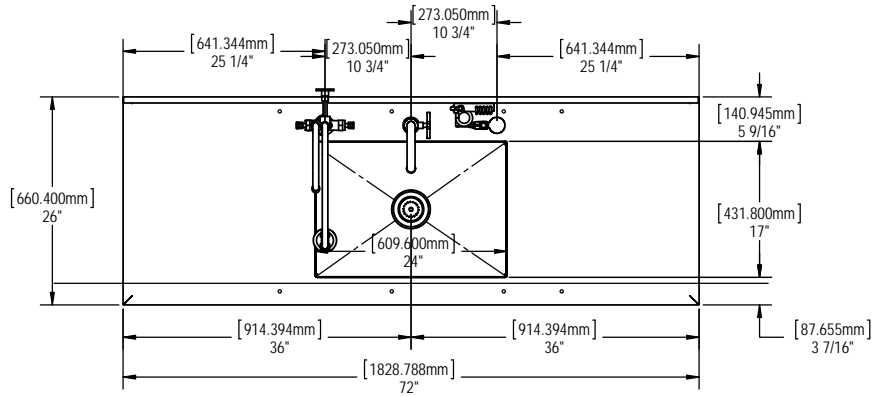

NOTES:

- FULLY WELDED 304 SERIES STAINLESS STEEL CONSTRUCTION
- PRE-RINSE FAUCETS: GOOSE-NECK WITH BUILT IN PRERINSE INLET - 1/2" NPSM MALE WITH COMPRESSION FITTINGS. OPERATING PRESSURE 20-125 PSI OPERATING TEMP RANGE 40-180° F
- TREATED (DI) WATER: FLOW RATE 50 PSI - 120 PSI, RATE OPERATING PRESSURE: 20-125 PSI, RATED OPERATING TEMPERATURE: 40-140°F, 1/2" NPSM MALE INLET, OPTIONAL ADAPTER FOR 1/4" NPT MALE INLET (INCLUDED)
- AIR INLET: TURRET BASE 3/8" NPT FEMALE INLET, SINGLE 3/8" NPT FEMALE OUTLET, 3/8" IPS MOUNTING SHANK WITH LOCKNUT AN WASHER, 3/8" PS X 2-1/2" OAL, LOW-PRESSURE BRASS THREADED PIPE FITTING 3/8 MALE X 1/4 FEM PIPE SIZE, HEX REDUCING BUSHING
- GOOSE NECK FAUCET: 1/2" NPSM MALE INLET
- SINK DRAIN: SINK OPENING DIAMETER 3-1/2", NPS: 1-1/2" FACE FLANGE DIAMETER: 4-1/2"
- UTILITY REQUIREMENT: COLD WATER - 20 TO 50 PSIG 70°F MAX, HOT WATER - 20 TO 50 PSIG 120°F TO 140°F.
- AIR GUN WITH STANDARD 5 TIP GUN & HOSE: CONNECTIONS ARE TO BE MADE PER LOCAL CODE & NOT TO EXCEED RECOMANDED 150 PSI, 1/4" NPTF INLET

AA	RELEASE FOR CUSTOMER APPROVAL		D.OUALLS	5/3/16
REV.	DESCRIPTION	ECO #	BY:	DATE
	REVISIONS			

WEIGHT (LBS) 170.10	THIRD ANGLE PROJECTION	INCHES	MATERIAL	FINISH
TITLE PROCESSING SINK SINGLE BASIN	DRAWING NUMBER FHCP267237-1-1-3-2			

TOLERANCES UNLESS OTHERWISE SPECIFIED		DATE
ANGLES: ±1°	DECIMALS: .XXX ± 0.03	5/3/16
FRACTIONS: ± 1/64	DECIMALS: .XXX ± 0.015	DATE
	XXX ± 0.005	DATE
DRAWN BY	CHECKED BY	DATE
APPROVED BY	DATE	DATE
SCALE 1:12	SHEET 1 OF 2	

CONFIDENTIAL & PROPRIETARY TO FMC NOT TO BE COPIED OR SHOWN TO ANYONE WITHOUT THE EXPRESS PERMISSION OF FMC

ANY PHYSICAL, DIMENSIONAL OR PERFORMANCE SPECIFICATIONS SHALL NOT BE REVISED WITHOUT WRITTEN AUTHORIZATION FROM MAC MEDICAL ENGINEERING

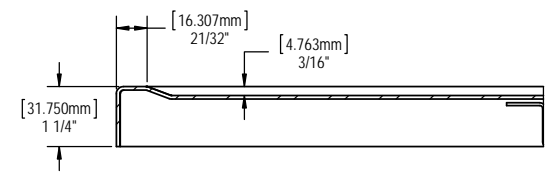
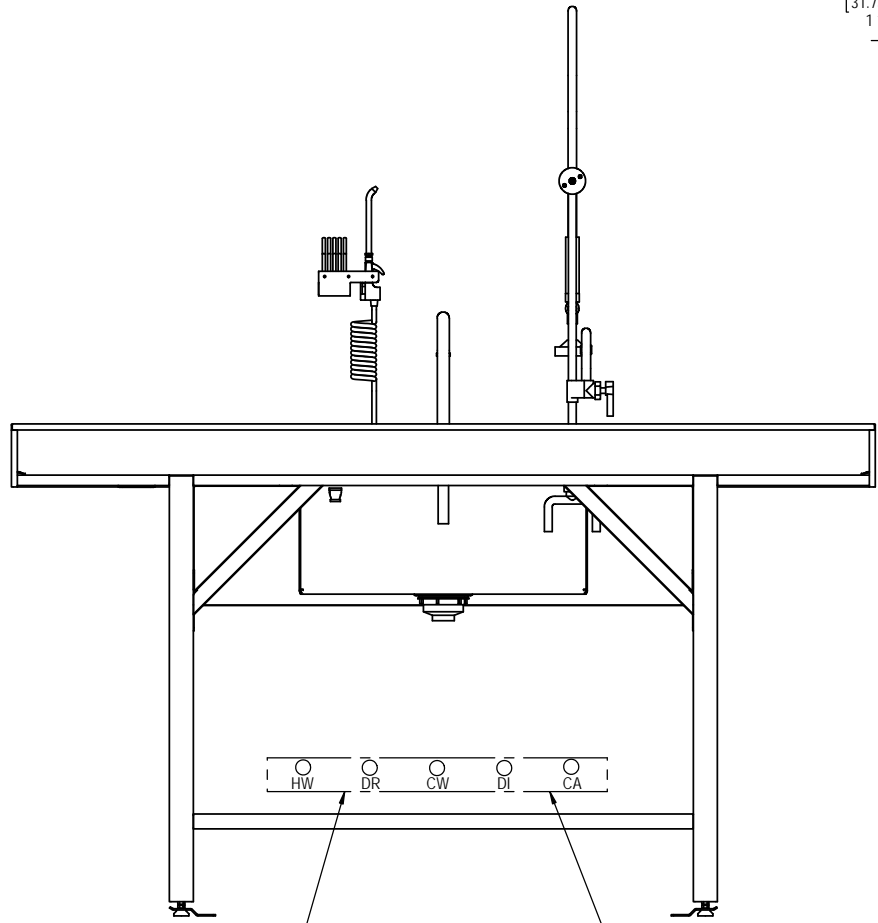

SECTION A-A
SCALE 1:2
MARINE EDGE DETAIL

CHECK LOCAL CODES FOR LOCATION

MECHANICAL CONTRACTOR TO CONNECT TO EXISTING FLOOR OR WALL DRAIN IN ACCORDANCE WITH APPLICABLE LOCAL CODE STANDARDS.

RECOMMENDATIONS:

1. UTILITY CONNECTION: BRAIDED HOSES ARE USED, THEY NEED TO HAVE 12" TO 13" OF PLAY IN ORDER TO ALLOW SINK TO RAISE AND LOWER.
2. CHECK ALL LOCAL CODES.

WEIGHT (LBS) 170.10	THIRD ANGLE PROJECTION	INCHES	MATERIAL	FINISH
------------------------	------------------------	--------	----------	--------

TITLE
PROCESSING SINK SINGLE BASIN

TOLERANCES UNLESS OTHERWISE SPECIFIED		DATE	
ANGLES: ±1°	DECIMALS: .XXX = ±.003	DATE	DATE
FRACTIONS: ± 1/64	DECIMALS: .XXX = ±.015	DATE	DATE
	DECIMALS: .XXX = ±.005	SCALE	SHEET
		1:12	2 OF 2

DRAWING NUMBER: **FHCPS267237-1-1-3-2**



CONFIDENTIAL & PROPRIETARY TO FHC. NOT TO BE COPIED OR SHOWN TO ANYONE WITHOUT THE EXPRESS PERMISSION OF FHC.