

APPROVAL TO BUILD
 SIGNATURE: _____
 TITLE: _____
 DATE: _____

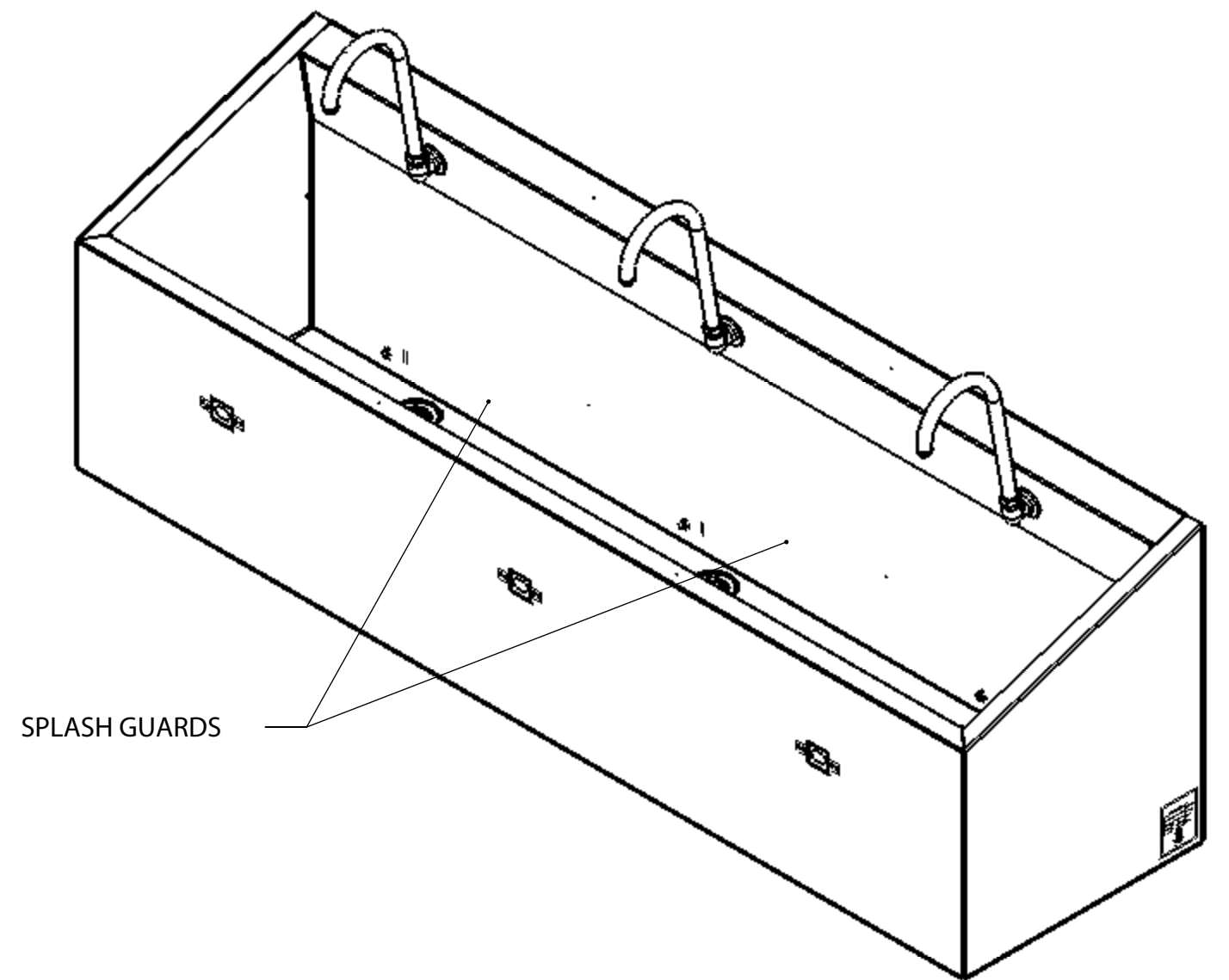

SPLASH GUARDS

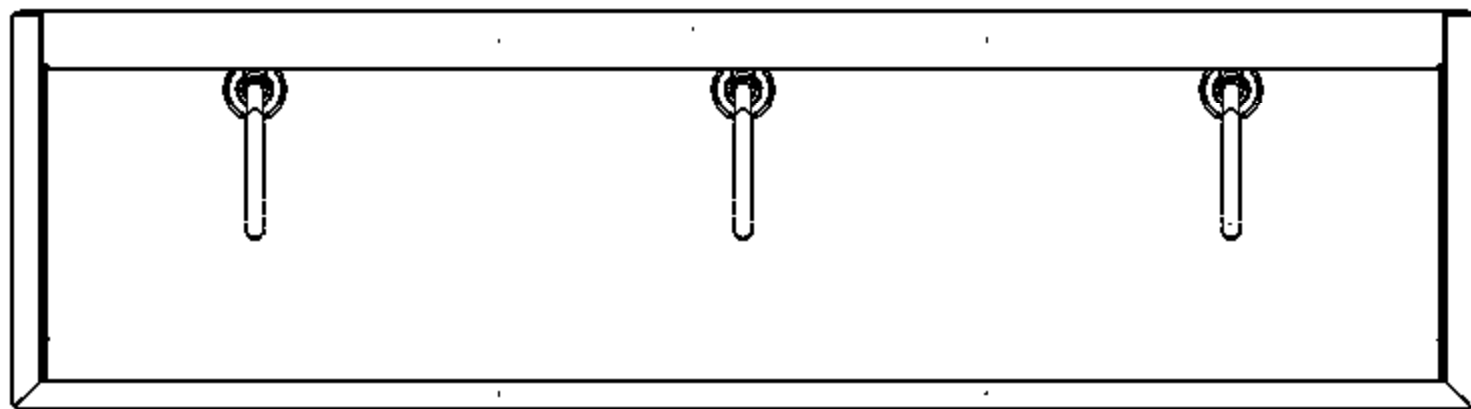
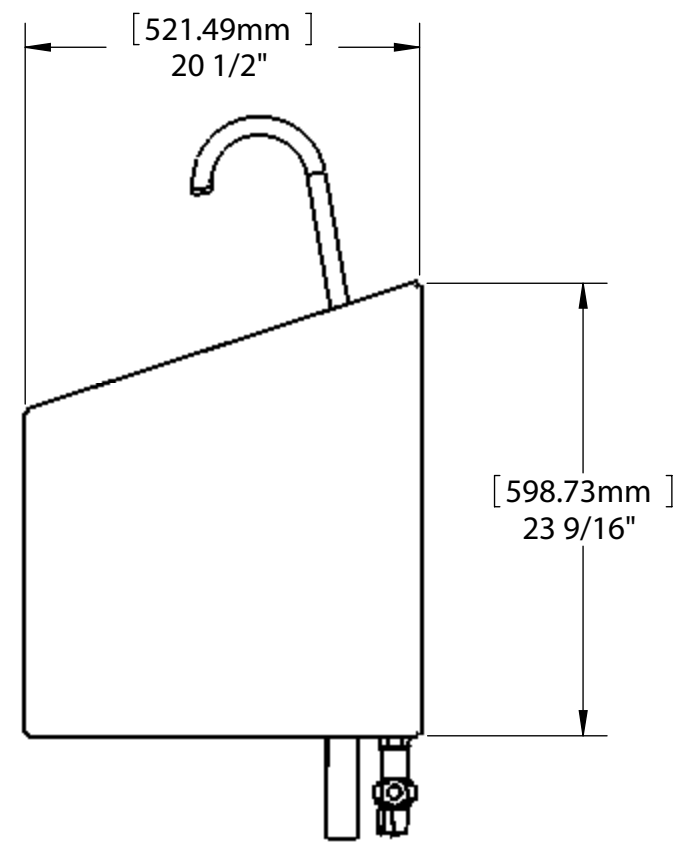
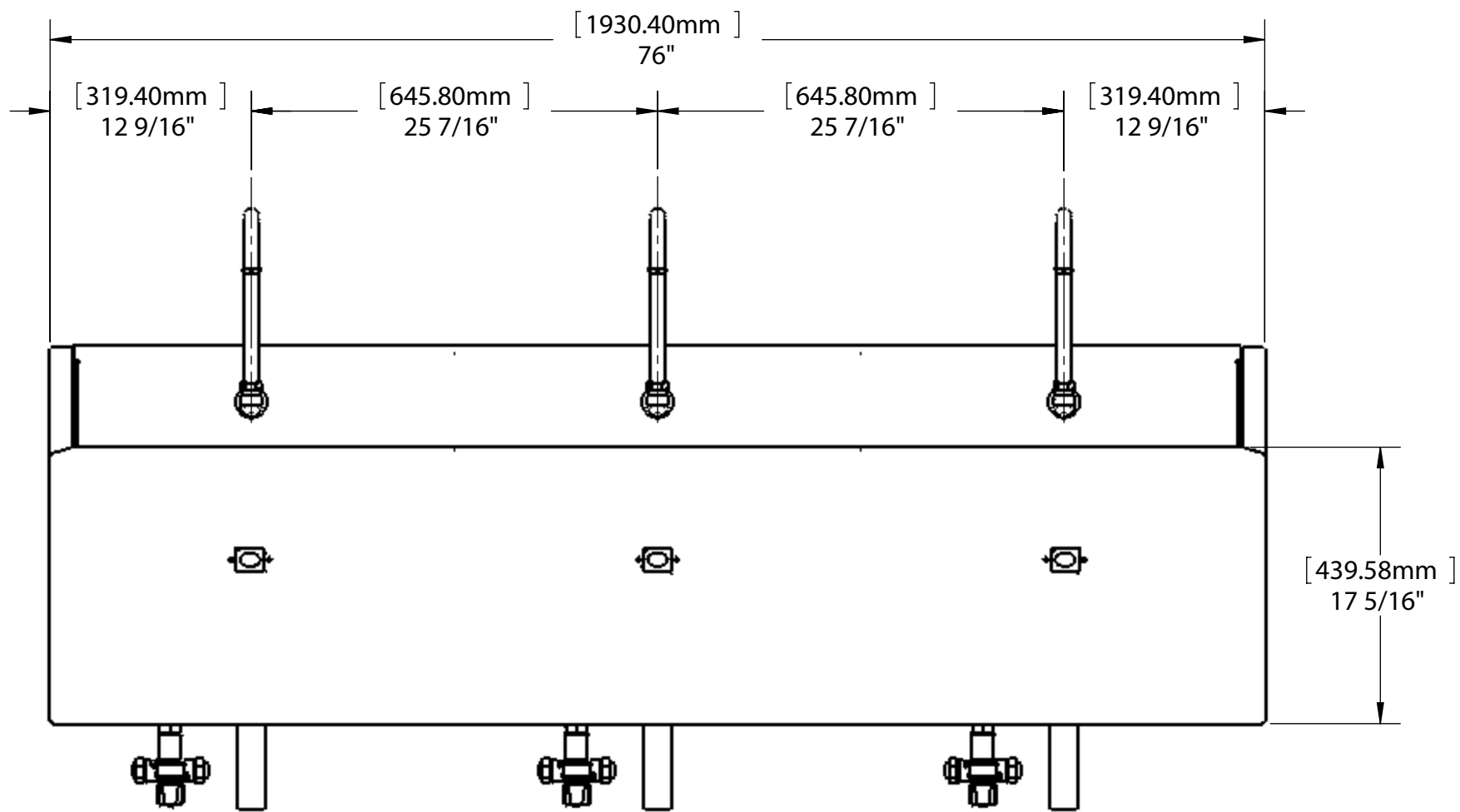

ANY PHYSICAL, DIMENSIONAL OR PERFORMANCE SPECIFICATIONS SHALL NOT BE REVISED WITHOUT WRITTEN AUTHORIZATION FROM FUTURE HEALTH ENGINEERING

THIRD ANGLE PROJECTION INCHES

CRITICAL TO QUALITY

TITLE
76" WIDE TRIPLE ECONOMY W/IR

TOLERANCES UNLESS OTHERWISE SPECIFIED
 ANGLES: ±1° .XX = ±.030
 FRACTIONS: ± 1/64 .XXX = ±.015
 .XXXX = ±.005

| | |
|----------------------------------|-------------------|
| DRAWN BY J. HERMANN | DATE 8/11/2010 |
| CHANGED BY | ECO # |
| CHECKED BY | DATE |
| SCALE 1:12 | SHEET 1 OF 2 |
| DRAWING NUMBER ES76-IR | |

CONFIDENTIAL & PROPRIETARY TO FUTURE HEALTH CONCEPTS NOT TO BE COPIED OR SHOWN TO ANYONE WITHOUT THE EXPRESS PERMISSION OF FUTURE HEALTH CONCEPTS, INC.

| | | | |
|-----------|-------------------|-------------|-----------|
| | CUSTOMER APPROVAL | JOHN H. | 8/11/2010 |
| REV. | DESCRIPTION | CHANGED BY: | DATE |
| REVISIONS | | | |